

CATV

77EYA Series High Power Er/Yb Doped Fiber Amplifier



■ Performance characteristics

- ◆ Erbium-Ytterbium co-doped double-clad fiber technology and low-noise pump lasers.
- ◆ With display backlight control function, the user can adjust the backlight time as needed.
- ◆ With perfect sound and light alarm function, support dual alarm of indicator light and buzzer.
- ◆ The entire EDFA adopts modular design, making it easy to maintain and manage.
- ◆ Standard network management interface, support WEB network management and SNMP, WEB interface is rich in functions.
- ◆ The 2U product supports total output power up to 41dBm, and supports the output power adjustable function with an adjustable range of +0.5~-4dBm.
- ◆ Optical switch, optical transmitter, RF monitoring and other functions are optional.
- ◆ Optional WDM for triple play function.
- ◆ Dual power supply with one-touch pull-out and hot backup design.
- ◆ Optional time control function and mobile phone remote monitoring function are available.

■ Applications

77EYAx Ytterbium-Erbium series of fiber amplifiers is a high power, multi-output fiber amplifier with a gain spectral bandwidth of 1545-1560nm, designed for CATV or 1-8 consecutive band channels (ITU wavelengths) applications. It provides a flexible and low-cost solution for FTTH coverage of CATV systems in large and medium-sized cities.

77EYAx can achieve single wavelength transmission of CATV signals, or built-in FWDM to achieve single-fibre three-wave transmission design, which is an important equipment for building CATV large and medium-sized optical fibre transmission networks.

■ Technical parameters

Item		Unit	Technical parameters	Remark
CATV working wavelength		nm	1545~1560	centre wavelength 1550nm
PON OLT working wavelength		nm	1270/1310/1490/1577	
CATV Input power		dBm	-5dBm~+10dBm	Limit -10dBm~+10dBm
Maximum total optical output power		dBm	41	
Output power stability		dB	±0.1	
Noise		dB	≤ 6	
Reflective loss	Input	dB	≥ 45	
	Output	dB	≥ 45	
OSW	Input port		2	Optional Features
	insertion loss	dB	≤1.2	
	switching time	s	<0.5	
Direct - Modulation transmitter	working wavelength	nm	1550	Optional Features
	Input level	dBuV	75~90	
	Output power	dBm W	3/5/7/10	
Output ports	straight	SC	unit	4~64
		LC		4~64
Output power per port		dBm	13~23	
RF test	Output level	dBuV	≥56	Optional Features
Optical connector			SC/APC; SC/PC; LC/APC; LC/PC	Customized
C/N		dB	≥ 50	Test conditions are performed according to GD / J115-2020
C/CTB		dB	≥ 65	
C/CSO		dB	≥ 65	
Supply voltage		V	AC(90V ~ 264V)	Optional DC (DC: 36~72V)
Power Consumption		W	< 150	
Operating Temperature Range		°C	-5 - +50	
Maximum working relative humidity		%	Maximum 95% non-condensing	
Storage temperature range		°C	-40 ~ +80	
Maximum storage relative humidity		%	Maximum storage relative humidity	
Product net size		mm	480(W)*428(D)*89(H)	Don't include handles
Package dimension(1 unit)		mm	610(W)*590(D)*155(H)	

■ Model guide

77EYA2-Output port*Per port output power-Input optical connector+Main power supply voltage+Sub power supply voltage+Output optical connector-with WDM+WDM

connector (**Note: When the black box has no order requirement, do not write**)

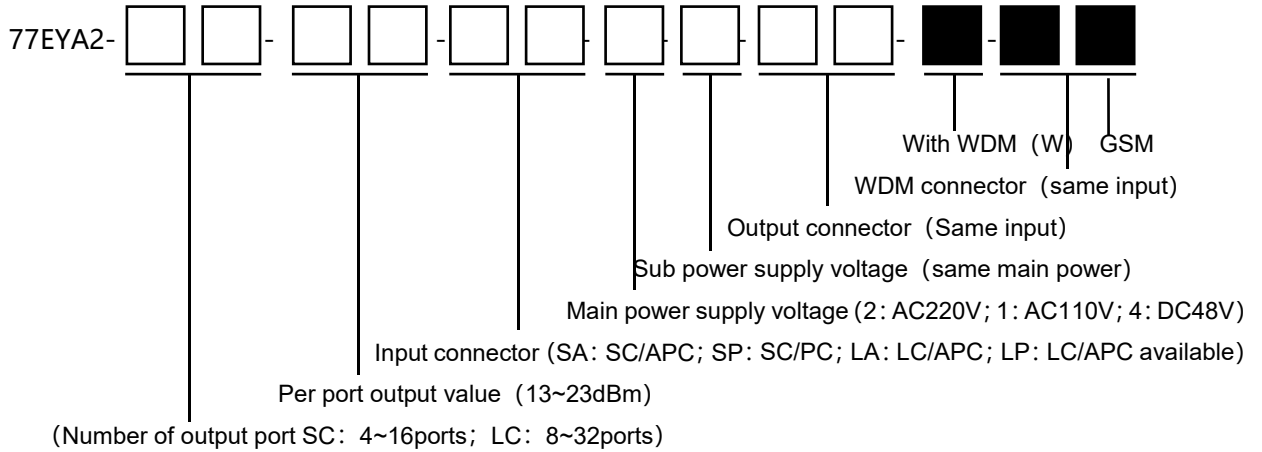

Example: 77EYA2-32*22-SA24SA-WSP

Explanation: This 77EYA 2U device is the erbium and ytterbium Co-doped high power fiber amplifier with 32 ports outputs, output power of each port 22dBm, input SC/APC connector, Main power voltage 220V, Sub power supply 48V, output SC/APC connector, with WDM, WDM SC/PC connector.

■ Package & Label

